

R15IB3S-65A1FTP

15" Intel® Celeron® N2930 IP65 Stainless PCAP Chassis Panel PC



KEY FEATURES

- Full IP65 dust/water resistant
- Robust and fanless design for reliable operation
- Fanless Colling System and Ultra Low power consumption
- Support Intel® Celeron® N2930 Processor
- SUS 316/ AISI 316 stainless steel for food and chemical industries
- Special Flat Touch Design easy to maintain
- Projective Capacitive Touch
- Optical bonding (optional)

INTRODUCTION

Winmate IP65 Stainless PCAP Chassis Panel PC Series is designed for demanding environments like food and chemical industries, offering sizes from 10.4" to 24". Built with SUS 316/AISI 316 stainless steel and sealed to IP65 standards, these panel PCs provide exceptional durability and protection against water and dust. Featuring a flat, edge-to-edge multi-touch design with P-Cap technology, superior readability, and glove/rain mode support, they ensure seamless operation. With robust fanless cooling, optical bonding options, and versatile mounting solutions, they deliver reliable performance in harsh and hygienic applications.

SPECIFICATIONS

Display

Resolution	1024x768	Size	15.0 inches
Contrast Ratio	2500:1	Panel Brightness	500.0 nits
View Angles	88,88,88,88	Active Area	304.1x228.1 mm
Touch / Glass	Projected Capacitive Multi Touch Screen		

System Specification

Processor	Intel Celeron N2930 1.83GHz (up to 2.16GHz)	Memory	1 x SO-DIMM, DDR3L 1600 MHz, 4GB 8GB (Optional)
Storage	1 x mSATA SSD 128GB 256GB (Optional) 512GB (Optional)	Ethernet controller	2 x Intel® Ethernet Controller
Operating System	Windows 10 IoT Enterprise (64 bit) (Optional) Linux Ubuntu 20.04 (Optional)	WLAN	Support (Optional)
BT	Support (Optional)		

Mechanical

Dimension	396 x 310 x 49 mm	Weight	5.7 kg
Mounting	VESA Mount	Enclosure	Stainless Housing
Cooling System	Fanless design		

Environment

Operating Humidity	10% to 90% RH, Non-Condensing	Operating Temperature	0°C to 45°C
---------------------------	-------------------------------	------------------------------	-------------

Storage Temperature -20°C to 60°C IP rating IP65

Certification

Certification CE, FCC

IO Ports

Power Input	1 x M12 waterproof connector for 12V DC	USB Port	1x M12 waterproof connector for 2 x USB2.0
Serial Port	1 x M12 waterproof connector for RS232	LAN	1 x waterproof Giga LAN RJ45 connector
Indicator	1 x LED Indicator for power 1 x LED Indicator for storage		

Control

Button 1 x Power Button
1 x Reset Button

Accessory

Accessory External USB cable with waterproof connector
External COM cable with waterproof connector
External LAN cable with waterproof connector
Waterproof caps
VESA screws
100~240V AC to DC Adapter with waterproof connector
Power Cord

Power

Power Rating 12V DC (M12 type)

DIMENSIONS UNIT:MM

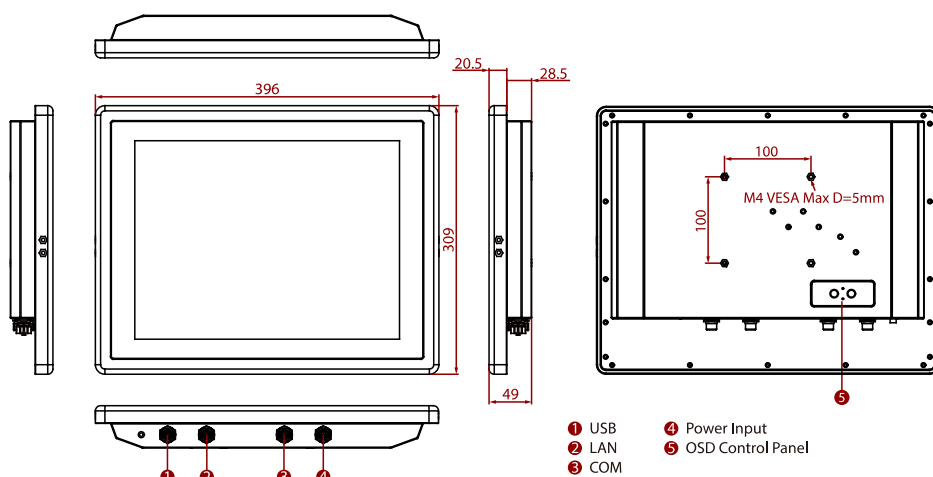

NOTE

1. This is a simplified drawing and some components are not marked in detail.
2. Windows 10 operating system requires installing a new version of BIOS and OS image.
3. Windows 7 does not support the TPM 2.0 function.
4. The product shown in this datasheet is a standard model. For diagrams that contain customized or optional I/O, please contact the Winmate Sales Team for more information.
5. All specifications are subject to change without prior notice.